

Wil-
&
Ver-

BOILERS STEAM & HOT WATER **RIVERSIDE HYDRONICS**

liams
Davis
tical

Tubless Boiler
Sizes 10/20/30 Horsepower

High Pres-
Low Pres-
Low Pres-

Natural Gas
Propane
Oil Burners



sure Steam
sure Steam
sure Water

Burners
Burners

RIVERSIDE HYDRONICS
PRIMERA Boiler and Hot Water Heaters
400 MBTU/hr to 2,000 MBTU/hr
30 inch footprint all models
160 psi MAWP
Metal-fiber-matrix Low NOx burner

Finned-tube heat exchanger braze-welded
into 100% copper heads

to 150 psig
to 15 psig
0-160 psig

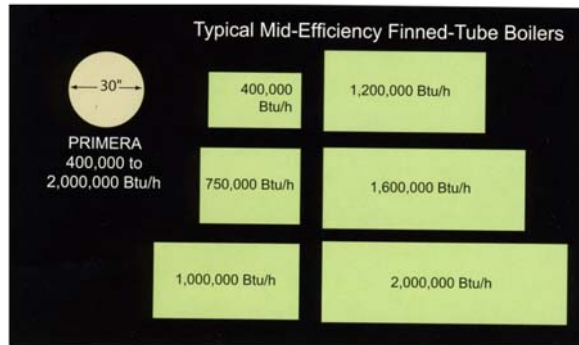

Motorized Turndown
Damper (modulation
and stage-firing)

Blower
Motor

Combustion
Air Inlet

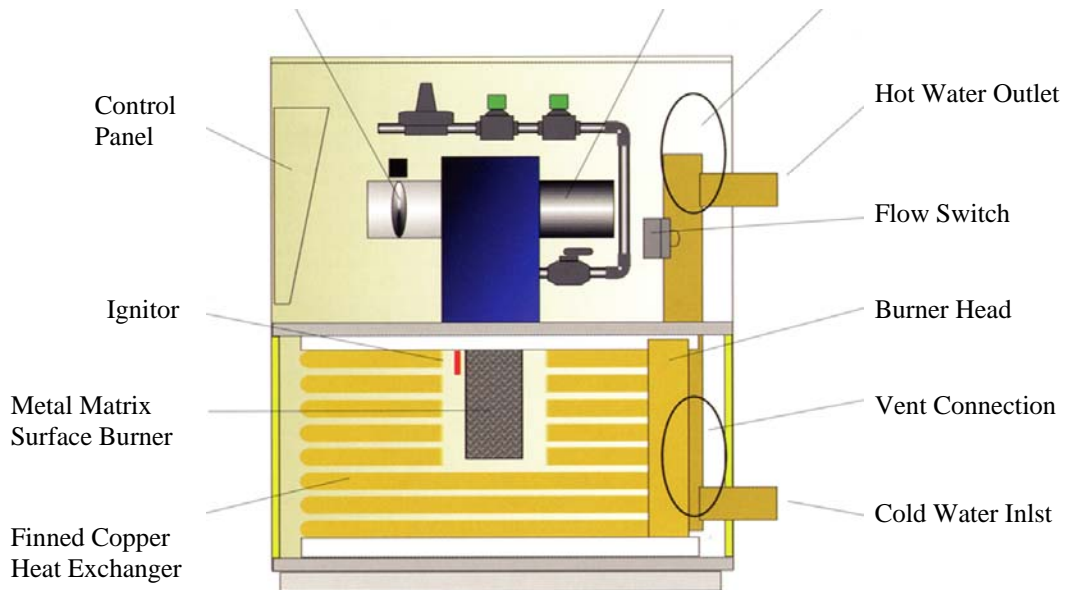

For prices on products or parts call us at 623-847-4788 or FAX 623-847-2386

***BOILERS STEAM & HOT WATER
GASMASTER BOILERS AND WATER HEATERS***

GASMASTER
Boiler or Water Heater
Up to 99.8% efficient
200 to 4,000 MBH / 58.6 to 1,172 kW
Stainless Steel Heat Exchanger
Condensing Steam Boilers
Less than 15 ppm NOx

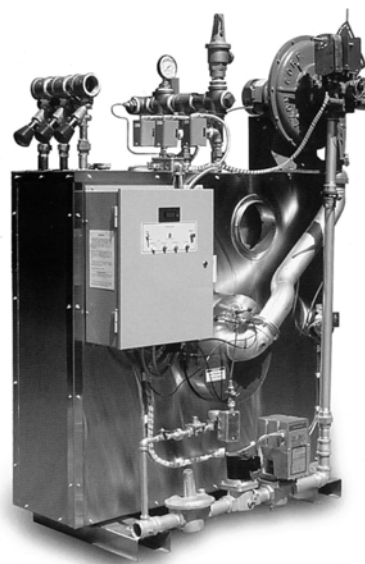

***BOILERS STEAM & HOT WATER
USED OR RE-CONDITIONED BOILERS AND WATER HEATERS
BY EMERSON BOILER INC
CALL 623-847-4788***



For prices on products or parts call us at 623-847-4788 or FAX 623-847-2386